

Interferon-alpha-Ab ELISA

Enzyme immunoassay for the quantitative determination of human anti-Interferon- α (anti-IFN- α) in cell culture supernatants, human serum, plasma and other biological fluids.

REF

BE51051



96



2-8 °C

EU: *For research use only.*

U.S.: *For research use only.
Not for use in diagnostic procedures.*



I B L I N T E R N A T I O N A L G M B H

Flughafenstrasse 52a
D-22335 Hamburg, Germany

Phone: +49 (0)40-53 28 91-0
Fax: +49 (0)40-53 28 91-11

IBL@IBL-International.com
www.IBL-International.com

TABLE OF CONTENTS

1	Intended Use	3
2	Summary	3
3	Principles of the Test	5
4	Reagents Provided	7
5	Storage Instructions – ELISA Kit	8
6	Specimen Collection and Storage Instructions	8
7	Materials Required But Not Provided	9
8	Precautions for Use	10
9	Preparation of Reagents	12
10	Test Protocol	16
11	Calculation of Results	21
12	Limitations	24
13	Performance Characteristics	25
14	Ordering Information	29
15	Reagent Preparation Summary	30
16	Test Protocol Summary	31

1 Intended Use

The human anti-IFN- α ELISA is an enzyme-linked immunosorbent assay for the quantitative detection of human anti-IFN- α . **The human anti-IFN- α ELISA is for research use only. Not for diagnostic or therapeutic procedures.**

2 Summary

Studies on antigenicity led to the concept that molecules like the interferons were not immunogenic in homologous systems because antibodies are not normally produced against "self" antigens. However, naturally occurring or therapeutically induced antibodies to cytokines such as interferons, tumor necrosis factors (TNF), interleukins (IL) and various growth factors were found, which are generally thought to inhibit cytokine functions, and the appearance of such antibodies should therefore result in various degrees of cytokine deficiency. It is a common concept that the development of antibodies against any auto-antigen or drug is always undesirable. Such antibodies are crucial for the pathology of autoimmune diseases and inhibit the pharmacological effects of drugs including exogenously administered cytokines.

Natural antibodies: Antibodies to IFN- α have been reported in patients with various autoimmune disorders.

Antibodies to IFN- α were detected in the serum of patients with systemic lupus erythematosus.

There are reports of natural antibodies to IFN- α in patients suffering from herpes zoster infections, and varicella zoster disease.

Spontaneous antibodies to IFN- α were shown to occur in sera of various cancer patients. Neutralizing IFN- α antibodies were also found in cerebrospinal fluids and sera of acute aseptic meningitis patients as well as in patients with chronic polyarthritis. There are data from several groups suggesting that elevated levels of antibodies to IFN- α are associated with stages of diseases related to dysbalances of the immune system. Accordingly, antibodies to IFN- α have been found in hemodialysis, kidney transplant patients, and HIV infected patients where the development of such antibodies appears to parallel disease progression.

Therapeutically induced antibodies: The immunogenic potential defined as capacity of epitopes to induce antibody formation of the recombinant and natural IFN- α preparations used in human therapy has attracted increasing interest in clinical research. Formation of antibodies against IFN- α has been reported in patients after treatment with all available human IFN preparations regardless of their composition and subtypes. More and more reports indicate that relapses after successful IFN- α therapy coincide the formation of neutralizing antibodies against IFN- α . Antibody formation depends on several factors which include the IFN- α preparation used in therapy, the therapeutic regimen, the duration of treatment and the type of disease.

Leukemias/lymphomas: Clinical resistance and IFN- α antibodies have been found in patients with hairy cell leukemia, chronic myeloid leukemia, chronic lymphoid leukemia, multiple myeloma, essential thrombocytemia, preleukemia, and Kaposi's sarcoma.

Solid tumors: Treatment of patients with solid tumors may also induce IFN- α antibody formation as shown for: malignant melanoma, renal cell carcinoma, nasopharyngeal carcinoma, breast carcinoma, various advanced carcinomas, urinary bladder carcinoma and genital as well as respiratory papillomatosis.

Furthermore there are neutralizing antibodies to IFN- α in response to therapy in chronic hepatitis B and C virus infection.

3 Principles of the Test

Recombinant human IFN- α is adsorbed onto microwells.

Figure 1

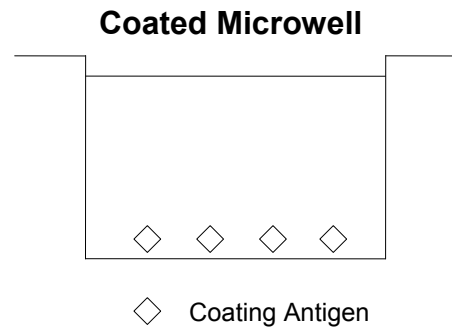

Human anti-IFN- α present in the sample or standard binds to the capture protein adsorbed to the microwells.

Figure 2

First Incubation

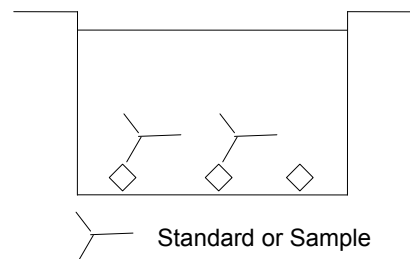

Following incubation unbound biological components are removed during a wash step and a HRP-conjugated human IFN- α protein is added and binds to human anti-IFN- α captured by the first human IFN- α protein.

Figure 3

Second Incubation

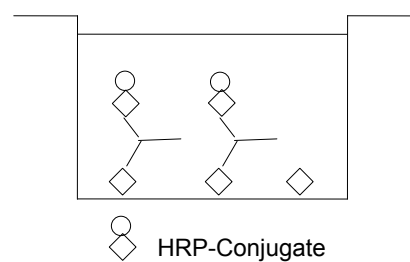

Following incubation unbound HRP-conjugated human IFN- α is removed during a wash step, and substrate solution reactive with HRP is added to the wells.

Figure 4

Third Incubation

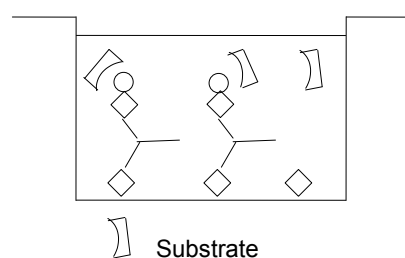

A coloured product is formed in proportion to the amount of human anti-IFN- α present in the sample or standard. The reaction is terminated by addition of acid and absorbance is measured at 450 nm. A standard curve is prepared from 7 human anti-IFN- α standard dilutions and human anti-IFN- α concentration determined.

Figure 5

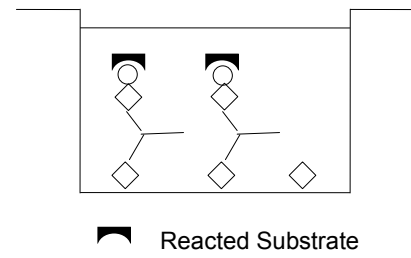

4 Reagents Provided

- 1 aluminium pouch with a **Microwell Plate coated** with recombinant human IFN- α
- 1 vial (200 μ l) **HRP-Conjugate** human IFN- α protein
- 2 vials (500 μ l) human anti-IFN- α **Standard**, 200 ng/ml
- 1 vial (5 ml) **Assay Buffer Concentrate 20x**
(PBS with 1% Tween 20 and 10% BSA)
- 1 bottle (50 ml) **Wash Buffer Concentrate 20x**
(PBS with 1% Tween 20)
- 1 vial (15 ml) **Substrate Solution** (tetramethyl-benzidine)
- 1 vial (15 ml) **Stop Solution** (1M Phosphoric acid)
- 1 vial (0.4 ml) **Blue-Dye**
- 1 vial (0.4 ml) **Green-Dye**
- 4 **Adhesive Films**

5 Storage Instructions – ELISA Kit

Store kit reagents between 2° and 8°C. Immediately after use remaining reagents should be returned to cold storage (2° to 8°C). Expiry of the kit and reagents is stated on labels.

Expiry of the kit components can only be guaranteed if the components are stored properly, and if, in case of repeated use of one component, this reagent is not contaminated by the first handling.

6 Specimen Collection and Storage Instructions

Cell culture supernatant, serum, plasma (EDTA, citrate, heparin) and urine were tested with this assay. Other biological samples might be suitable for use in the assay.

Remove serum or plasma from the clot or cells as soon as possible after clotting and separation.

Samples containing a visible precipitate must be clarified prior to use in the assay. Do not use grossly hemolyzed or lipemic specimens.

Samples should be aliquoted and must be stored frozen at -20°C to avoid loss of bioactive human anti-IFN- α . If samples are to be run within 24 hours, they may be stored at 2° to 8°C (for sample stability refer to 13.5).

Avoid repeated freeze-thaw cycles. Prior to assay, the frozen sample should be brought to room temperature slowly and mixed gently.

7 Materials Required But Not Provided

- 5 ml and 10 ml graduated pipettes
- 5 μ l to 1000 μ l adjustable single channel micropipettes with disposable tips
- 50 μ l to 300 μ l adjustable multichannel micropipette with disposable tips
- Multichannel micropipette reservoir
- Beakers, flasks, cylinders necessary for preparation of reagents
- Device for delivery of wash solution (multichannel wash bottle or automatic wash system)
- Microwell strip reader capable of reading at 450 nm (620 nm as optional reference wave length)
- Glass-distilled or deionized water
- Statistical calculator with program to perform regression analysis

8 Precautions for Use

- All chemicals should be considered as potentially hazardous. We therefore recommend that this product is handled only by those persons who have been trained in laboratory techniques and that it is used in accordance with the principles of good laboratory practice. Wear suitable protective clothing such as laboratory overalls, safety glasses and gloves. Care should be taken to avoid contact with skin or eyes. In the case of contact with skin or eyes wash immediately with water. See material safety data sheet(s) and/or safety statement(s) for specific advice.
- Reagents are intended for research use only and are not for use in diagnostic or therapeutic procedures.
- Do not mix or substitute reagents with those from other lots or other sources.
- Do not use kit reagents beyond expiration date on label.
- Do not expose kit reagents to strong light during storage or incubation.
- Do not pipette by mouth.
- Do not eat or smoke in areas where kit reagents or samples are handled.
- Avoid contact of skin or mucous membranes with kit reagents or specimens.
- Rubber or disposable latex gloves should be worn while handling kit reagents or specimens.
- Avoid contact of substrate solution with oxidizing agents and metal.
- Avoid splashing or generation of aerosols.
- In order to avoid microbial contamination or cross-contamination of reagents or specimens which may invalidate the test use disposable pipette tips and/or pipettes.
- Use clean, dedicated reagent trays for dispensing the conjugate and substrate reagent.

- Exposure to acid inactivates the conjugate.
- Glass-distilled water or deionized water must be used for reagent preparation.
- Substrate solution must be at room temperature prior to use.
- Decontaminate and dispose specimens and all potentially contaminated materials as they could contain infectious agents. The preferred method of decontamination is autoclaving for a minimum of 1 hour at 121.5°C.
- Liquid wastes not containing acid and neutralized waste may be mixed with sodium hypochlorite in volumes such that the final mixture contains 1.0% sodium hypochlorite. Allow 30 minutes for effective decontamination. Liquid waste containing acid must be neutralized prior to the addition of sodium hypochlorite.

9 Preparation of Reagents

Buffer Concentrates should be brought to room temperature and should be diluted before starting the test procedure.

If crystals have formed in the **Buffer Concentrates**, warm them gently until they have completely dissolved.

9.1 Wash Buffer (1x)

Pour entire contents (50 ml) of the **Wash Buffer Concentrate** (20x) into a clean 1000 ml graduated cylinder. Bring to final volume of 1000 ml with glass-distilled or deionized water. Mix gently to avoid foaming.

Transfer to a clean wash bottle and store at 2° to 25°C. Please note that Wash Buffer (1x) is stable for 30 days.

Wash Buffer (1x) may also be prepared as needed according to the following table:

Number of Strips	Wash Buffer Concentrate (20x) (ml)	Distilled Water (ml)
1 - 6	25	475
1 - 12	50	950

9.2 Assay Buffer (1x)

Pour the entire contents (5 ml) of the **Assay Buffer Concentrate** (20x) into a clean 100 ml graduated cylinder. Bring to final volume of 100 ml with distilled water. Mix gently to avoid foaming.

Store at 2° to 8°C. Please note that the Assay Buffer (1x) is stable for 30 days.

Assay Buffer (1x) may also be prepared as needed according to the following table:

Number of Strips	Assay Buffer Concentrate (20x) (ml)	Distilled Water (ml)
1 - 6	2.5	47.5
1 - 12	5.0	95.0

9.3 HRP-Conjugate

Please note that the HRP-Conjugate should be used within 30 minutes after dilution.

Make a 1:100 dilution of the concentrated **HRP-Conjugate** solution with Assay Buffer (1x) in a clean plastic tube as needed according to the following table:

Number of Strips	HRP-Conjugate (ml)	Assay Buffer (1x) (ml)
1 - 6	0.06	5.94
1 - 12	0.12	11.88

9.4 Human anti-IFN- α Standard

Standard dilutions can be prepared directly on the microwell plate (see 10.c) or alternatively in tubes (see 9.4.1).

9.4.1 External Standard Dilution

Label 6 tubes, one for each standard point.

S2, S3, S4, S5, S6, S7

Then prepare 1:2 serial dilutions for the standard curve as follows:

Pipette 225 μ l of Assay Buffer (1x) into tubes S2 – S7.

Pipette 225 μ l of undiluted standard (serves as the highest standard S1, concentration of standard 1= 200 ng/ml) into the first tube, labelled S2,

and mix (concentration of standard 2 = 100 ng/ml).

Pipette 225 μ l of this dilution into the second tube, labelled S3, and mix thoroughly before the next transfer.

Repeat serial dilutions 4 more times thus creating the points of the standard curve (see Figure 6).

Assay Buffer (1x) serves as blank.

Figure 6

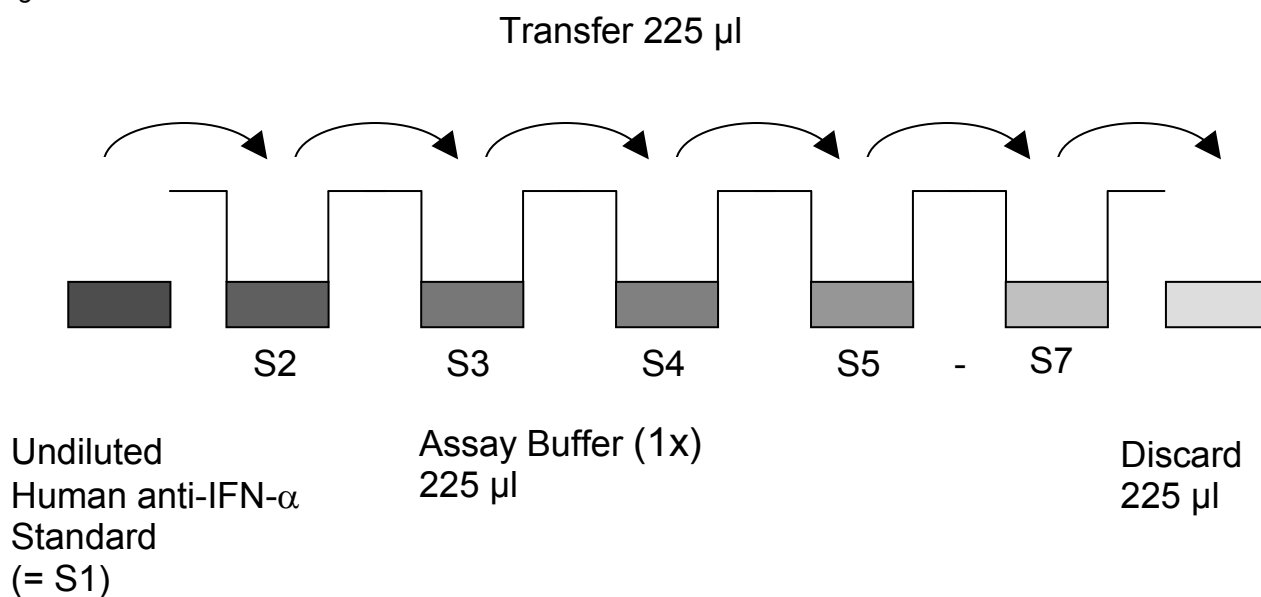

9.5 Addition of Colour-giving Reagents: Blue-Dye, Green-Dye

In order to help our customers to avoid any mistakes in pipetting the ELISAs, IBL International offers a tool that helps to monitor the addition of even very small volumes of a solution to the reaction well by giving distinctive colours to each step of the ELISA procedure.

This procedure is optional, does not in any way interfere with the test results, and is designed to help the customer with the performance of the test, but can also be omitted, just following the instruction booklet.

Alternatively, the dye solutions from the stocks provided (**Blue-Dye, Green-Dye**) can be added to the reagents according to the following guidelines:

1. Diluent:

Before standard and sample dilution add the **Blue-Dye** at a dilution of 1:250 (see table below) to the appropriate diluent (1x) according to the test protocol. After addition of **Blue-Dye**, proceed according to the instruction booklet.

5 ml Assay Buffer (1x)	20 μ l Blue-Dye
12 ml Assay Buffer (1x)	48 μ l Blue-Dye
50 ml Assay Buffer (1x)	200 μ l Blue-Dye

2. HRP-Conjugate:

Before dilution of the concentrated HRP-Conjugate add the **Green-Dye** at a dilution of 1:100 (see table below) to the Assay Buffer (1x) used for the final conjugate dilution. Proceed after addition of **Green-Dye** according to the instruction booklet: Preparation of HRP-Conjugate.

6 ml Assay Buffer (1x)	60 μ l Green-Dye
12 ml Assay Buffer (1x)	120 μ l Green-Dye

10 Test Protocol

- a. Determine the number of microwell strips required to test the desired number of samples plus appropriate number of wells needed for running blanks and standards. Each sample, standard, blank and optional control sample should be assayed in duplicate. Remove extra microwell strips from holder and store in foil bag with the desiccant provided at 2°-8°C sealed tightly.
- b. Wash the microwell strips twice with approximately 400 µl **Wash Buffer** per well with thorough aspiration of microwell contents between washes. Allow the Wash Buffer to sit in the wells for about **10 – 15 seconds** before aspiration. Take care not to scratch the surface of the microwells.
After the last wash step, empty wells and tap microwell strips on absorbent pad or paper towel to remove excess Wash Buffer. Use the microwell strips immediately after washing. Alternatively microwell strips can be placed upside down on a wet absorbent paper for not longer than 15 minutes. **Do not allow wells to dry.**
- c. **Standard dilution on the microwell plate** (Alternatively the standard dilution can be prepared in tubes - see 9.4.1):
Add 100 µl of Assay Buffer (1x) in duplicate to **standard wells** B1/2-G1/2, leaving A1/A2 empty. Pipette 200 µl of undiluted **standard** (concentration = 200.0 ng/ml) in duplicate into well A1 and A2 (see Table 1). Mix the contents of wells B1 and B2 by repeated aspiration and ejection, and transfer 100 µl to wells C1 and C2, respectively. (see Figure 7). Take care not to scratch the inner surface of the microwells. Continue this procedure 4 times, creating two rows of human anti-IFN- α standard dilutions ranging from 200.0 to 3.1 ng/ml. Discard 100 µl of the contents from the last microwells (G1, G2) used.

Figure 7

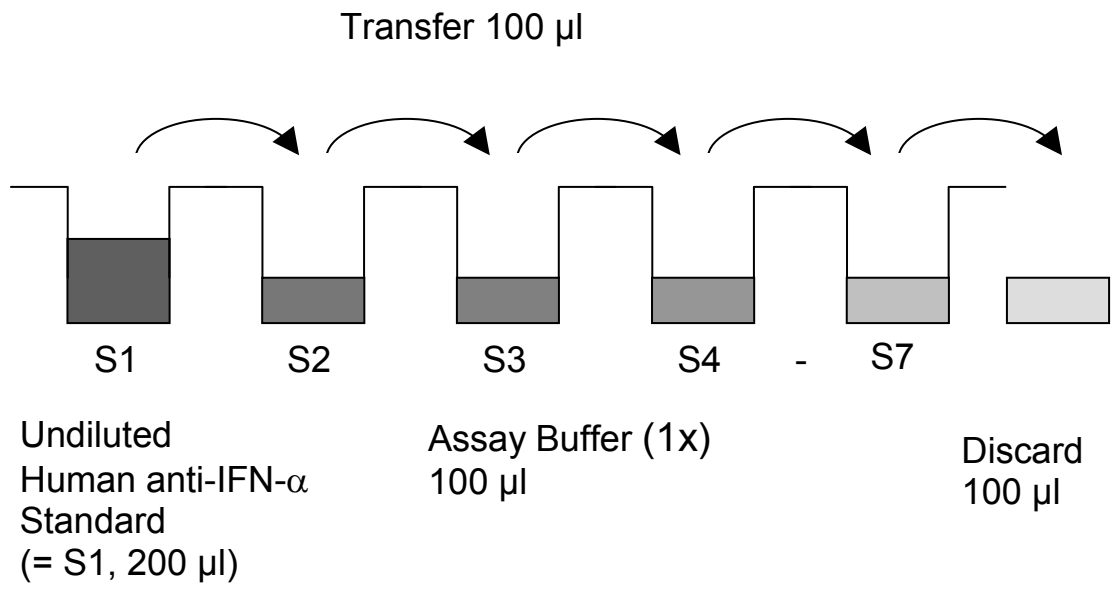

In case of an **external standard dilution** (see 9.4.1), pipette 100 µl of these standard dilutions (S1 - S7) in the standard wells according to Table 1.

Table 1

Table depicting an example of the arrangement of blanks, standards and samples in the microwell strips:

	1	2	3	4
A	Standard 1 (200.0 ng/ml)	Standard 1 (200.0 ng/ml)	Sample 1	Sample 1
B	Standard 2 (100.0 ng/ml)	Standard 2 (100.0 ng/ml)	Sample 2	Sample 2
C	Standard 3 (50.0 ng/ml)	Standard 3 (50.0 ng/ml)	Sample 3	Sample 3
D	Standard 4 (25.0 ng/ml)	Standard 4 (25.0 ng/ml)	Sample 4	Sample 4
E	Standard 5 (12.5 ng/ml)	Standard 5 (12.5 ng/ml)	Sample 5	Sample 5
F	Standard 6 (6.3 ng/ml)	Standard 6 (6.3 ng/ml)	Sample 6	Sample 6
G	Standard 7 (3.1 ng/ml)	Standard 7 (3.1 ng/ml)	Sample 7	Sample 7
H	Blank	Blank	Sample 8	Sample 8

- d. Add 100 µl of **Assay Buffer (1x)** in duplicate to the **blank wells**.
- e. Add 80 µl of **Assay Buffer (1x)** to the **sample wells**.
- f. Add 20 µl of each **sample** in duplicate to the **sample wells**.
- g. Cover with an adhesive film and incubate at room temperature (18 to 25°C) for 2 hours, if available on a microplate shaker set at 200 rpm.
- h. Prepare **HRP-Conjugate** (see Preparation of HRP-Conjugate 9.3).
- i. Remove adhesive film and empty wells. **Wash** microwell strips 6 times according to point b. of the test protocol. Proceed immediately to the next step.
- j. Add 100 µl of **HRP-Conjugate** to all wells.
- k. Cover with an adhesive film and incubate at room temperature (18 to 25°C) for 1 hour, if available on a microplate shaker set at 200 rpm.
- l. Remove adhesive film and empty wells. **Wash** microwell strips 6 times according to point b. of the test protocol. Proceed immediately to the next step.
- m. Pipette 100 µl of **TMB Substrate Solution** to all wells.
- n. Incubate the microwell strips at room temperature (18° to 25°C) for about 10 min. Avoid direct exposure to intense light.

The colour development on the plate should be monitored and the substrate reaction stopped (see next point of this protocol) before positive wells are no longer properly recordable. Determination of the ideal time period for colour development has to be done individually for each assay.

It is recommended to add the stop solution when the highest standard has developed a dark blue colour. Alternatively the colour development can be monitored by the ELISA reader at 620 nm. The substrate reaction should be stopped as soon as Standard 1 has reached an OD of 0.9 – 0.95.

- o. Stop the enzyme reaction by quickly pipetting 100 µl of **Stop Solution** into each well. It is important that the Stop Solution is spread quickly and uniformly throughout the microwells to completely

inactivate the enzyme. Results must be read immediately after the Stop Solution is added or within one hour if the microwell strips are stored at 2 - 8°C in the dark.

- p. Read absorbance of each microwell on a spectro-photometer using 450 nm as the primary wave length (optionally 620 nm as the reference wave length; 610 nm to 650 nm is acceptable). Blank the plate reader according to the manufacturer's instructions by using the blank wells. Determine the absorbance of both the samples and the standards.

Note: In case of incubation without shaking the obtained O.D. values may be lower than indicated below. Nevertheless the results are still valid.

11 Calculation of Results

- Calculate the average absorbance values for each set of duplicate standards and samples. Duplicates should be within 20 per cent of the mean value.
- Create a standard curve by plotting the mean absorbance for each standard concentration on the ordinate against the human anti-IFN- α concentration on the abscissa. Draw a best fit curve through the points of the graph (a 5-parameter curve fit is recommended).
- To determine the concentration of circulating human anti-IFN- α for each sample, first find the mean absorbance value on the ordinate and extend a horizontal line to the standard curve. At the point of intersection, extend a vertical line to the abscissa and read the corresponding human anti-IFN- α concentration.
- **If instructions in this protocol have been followed samples have been diluted 1:5 (20 μ l sample + 80 μ l Assay Buffer (1x)), the concentration read from the standard curve must be multiplied by the dilution factor (x 5).**
- **Calculation of samples with a concentration exceeding standard 1 may result in incorrect human anti-IFN- α levels. Such samples require further external predilution according to expected human anti-IFN- α values with Assay Buffer (1x) in order to precisely quantitate the actual human anti-IFN- α level.**
- It is suggested that each testing facility establishes a control sample of known human anti-IFN- α concentration and runs this additional control with each assay. If the values obtained are not within the expected range of the control, the assay results may be invalid.
- A representative standard curve is shown in Figure 8. This curve cannot be used to derive test results. Each laboratory must prepare a standard curve for each group of microwell strips assayed.

Figure 8

Representative standard curve for human anti-IFN- α ELISA. Human anti-IFN- α was diluted in serial 2-fold steps in Assay Buffer (1x). Do not use this standard curve to derive test results. A standard curve must be run for each group of microwell strips assayed.

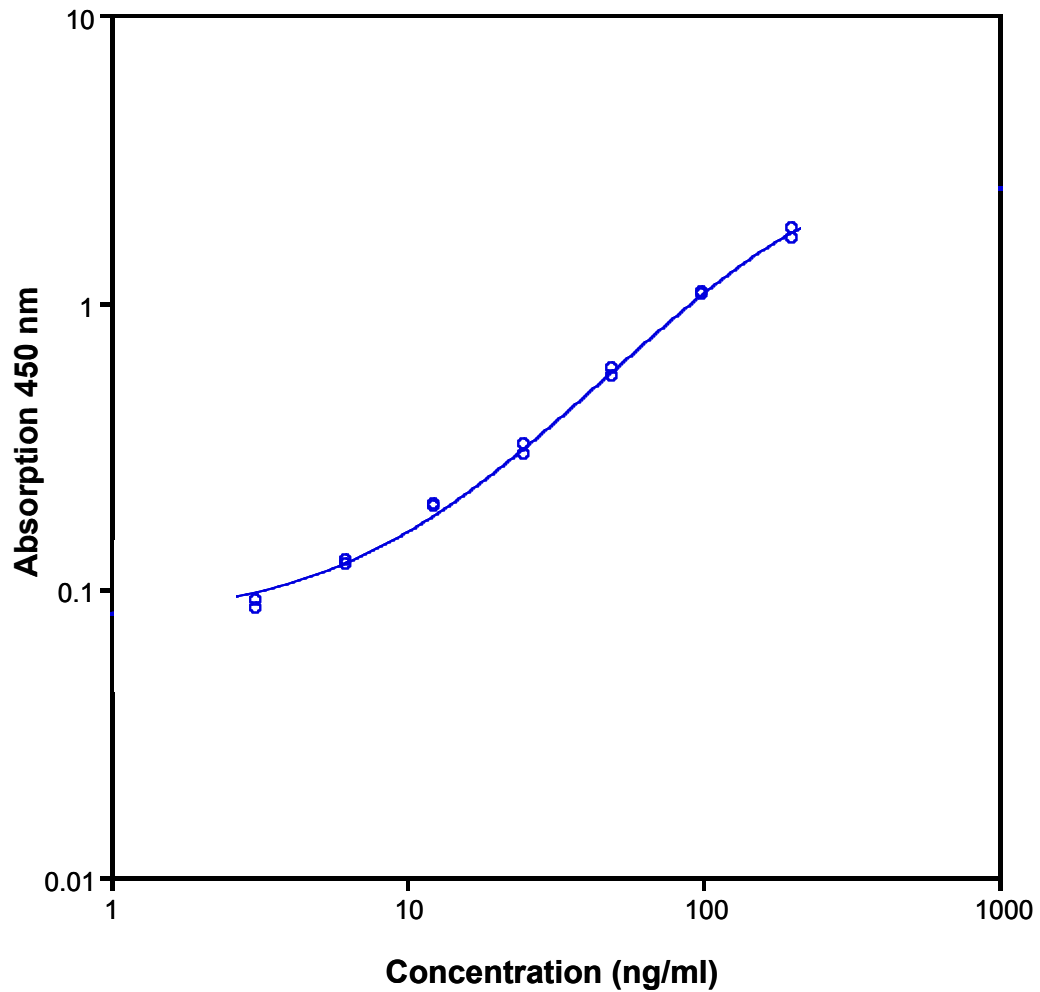

Table 2

Typical data using the human anti-IFN- α ELISA

Measuring wavelength: 450 nm

Reference wavelength: 620 nm

Standard	Human anti-IFN- α Concentration (ng/ml)	O.D. at 450 nm	Mean O.D. at 450 nm	C.V. (%)
1	200.0	1.670	1.737	3.8
	200.0	1.803		
2	100.0	1.061	1.066	0.5
	100.0	1.071		
3	50.0	0.546	0.567	3.7
	50.0	0.588		
4	25.0	0.321	0.308	4.4
	25.0	0.294		
5	12.5	0.195	0.197	0.8
	12.5	0.198		
6	6.3	0.122	0.124	1.2
	6.3	0.125		
7	3.1	0.085	0.089	4.0
	3.1	0.092		
Blank	0	0.050	0.049	2.0
	0	0.048		

The OD values of the standard curve may vary according to the conditions of assay performance (e.g. operator, pipetting technique, washing technique or temperature effects). Furthermore shelf life of the kit may affect enzymatic activity and thus colour intensity. Values measured are still valid.

12 Limitations

- Since exact conditions may vary from assay to assay, a standard curve must be established for every run.
- Bacterial or fungal contamination of either screen samples or reagents or cross-contamination between reagents may cause erroneous results.
- Disposable pipette tips, flasks or glassware are preferred, reusable glassware must be washed and thoroughly rinsed of all detergents before use.
- Improper or insufficient washing at any stage of the procedure will result in either false positive or false negative results. Empty wells completely before dispensing fresh wash solution, fill with Wash Buffer as indicated for each wash cycle and do not allow wells to sit uncovered or dry for extended periods.

13 Performance Characteristics

13.1 Sensitivity

The limit of detection of human anti-IFN- α defined as the analyte concentration resulting in an absorbance significantly higher than that of the dilution medium (mean plus 2 standard deviations) was determined to be 1.4 ng/ml (mean of 6 independent assays).

13.2 Reproducibility

13.2.1 Intra-assay

Reproducibility within the assay was evaluated in 3 independent experiments. Each assay was carried out with 6 replicates of 8 serum samples (spiked and unspiked) containing different concentrations of human anti-IFN- α . 2 standard curves were run on each plate. Data below show the mean human anti-IFN- α concentration and the coefficient of variation for each sample (see Table 3). The calculated overall intra-assay coefficient of variation was 3.3%.

Table 3

The mean human anti-IFN- α concentration and the coefficient of variation for each sample

Sample	Experiment	Mean Human anti-IFN- α Concentration (ng/ml)	Coefficient of Variation (%)
1	1	801.5	0.5
	2	769.1	2.5
	3	769.6	4.8
2	1	494.8	4.5
	2	533.6	3.4
	3	512.8	1.6
3	1	384.9	3.1
	2	365.9	3.2
	3	397.7	1.4
4	1	136.1	3.2
	2	132.8	3.4
	3	143.5	2.0
5	1	67.1	1.1
	2	64.8	2.8
	3	70.8	4.4
6	1	81.1	6.8
	2	79.9	4.1
	3	88.1	5.5
7	1	47.5	1.1
	2	47.4	5.1
	3	48.6	2.5
8	1	43.3	4.5
	2	42.6	2.7
	3	48.3	4.7

13.2.2 Inter-assay

Assay to assay reproducibility within one laboratory was evaluated in 3 independent experiments. Each assay was carried out with 6 replicates of 8 serum samples (spiked and unspiked) containing different concentrations of human anti-IFN- α . 2 standard curves were run on each plate. Data below show the mean human anti-IFN- α concentration and the coefficient of variation calculated on 18 determinations of each sample (see Table 4). The calculated overall inter-assay coefficient of variation was 4.1%.

Table 4

The mean human anti-IFN- α concentration and the coefficient of variation of each sample

Sample	Mean Human anti-IFN- α Concentration (ng/ml)	Coefficient of Variation (%)
1	780.1	2.4
2	513.7	3.8
3	382.8	4.2
4	137.5	4.0
5	67.6	4.5
6	83.0	5.4
7	47.8	1.4
8	44.8	7.0

13.3 Spike Recovery

The spike recovery was evaluated by spiking 4 levels of human anti-IFN- α into pooled normal human serum samples. Recoveries were determined in 3 independent experiments with 6 replicates each. The unspiked serum was used as blank in these experiments. The recovery ranged from 84% to 98% with an overall mean recovery of 92%.

Spiking in individual patient sera may result in lower recoveries.

13.4 Dilution Parallelism

4 spiked and 1 unspiked serum samples with different levels of human anti-IFN- α were analysed at serial 2 fold dilutions with 4 replicates each. The recovery ranged from 99% to 113% with an overall recovery of 104% (see Table 5).

Table 5

Sample	Dilution	Expected Human anti-IFN- α Concentration (ng/ml)	Observed Human anti-IFN- α Concentration (ng/ml)	Recovery of Expected Human anti-IFN- α Concentration (%)
1	1:5	--	506.8	--
	1:10	253.4	255.4	101
	1:20	127.7	131.6	103
2	1:5	--	324.2	--
	1:10	162.1	169.5	105
	1:20	84.8	88.4	104
3	1:5	--	210.6	--
	1:10	105.3	103.7	99
	1:20	51.9	53.7	104
4	1:5	--	116.9	--
	1:10	58.4	61.9	106
	1:20	31.0	32.3	104
5	1:5	--	381.6	--
	1:10	190.8	194.7	102
	1:20	97.4	110.3	113
	1:40	55.2	54.5	99

13.5 Sample Stability

13.5.1 Freeze-Thaw Stability

Aliquots of spiked serum samples were stored at -20°C and thawed 5 times, and the human anti-IFN- α levels determined. A significant decrease of human anti-IFN- α immunoreactivity (10%) was detected. Therefore samples should be stored in aliquots at -20°C and thawed only once.

13.5.2 Storage Stability

Aliquots of spiked serum samples were stored at -20°C , $2-8^{\circ}\text{C}$, room temperature (RT) and at 37°C , and the human anti-IFN- α level determined after 24 h. There was no significant loss of human anti-IFN- α immunoreactivity detected during storage under above conditions.

13.6 Specificity

The assay detects human antibodies to IFN- α . To define the specificity of this ELISA several human immunoglobulins to different polypeptides were tested for cross reactivity. There was no crossreactivity detected.

13.7 Expected Values

A panel of 57 serum samples from randomly selected apparently healthy donors (males and females) and patients suffering from various diseases was tested for human anti-IFN- α .

The detected human anti-IFN- α levels ranged between 0 and 120.5 ng/ml with a mean level of 17.4 ng/ml and a standard deviation of 26.7 ng/ml.

14 Ordering Information

See last page.

15 Reagent Preparation Summary

15.1 Wash Buffer (1x)

Add **Wash Buffer Concentrate** 20x (50 ml) to 950 ml distilled water.

Number of Strips	Wash Buffer Concentrate (ml)	Distilled Water (ml)
1 - 6	25	475
1 - 12	50	950

15.2 Assay Buffer (1x)

Add **Assay Buffer Concentrate** 20x (5 ml) to 95 ml distilled water.

Number of Strips	Assay Buffer Concentrate (ml)	Distilled Water (ml)
1 - 6	2.5	47.5
1 - 12	5.0	95.0

15.3 HRP-Conjugate

Make a 1:100 dilution of **HRP-Conjugate** in Assay Buffer (1x):

Number of Strips	HRP-Conjugate (ml)	Assay Buffer (1x) (ml)
1 - 6	0.06	5.94
1 - 12	0.12	11.88

16 Test Protocol Summary

1. Determine the number of microwell strips required.
2. Wash microwell strips twice with Wash Buffer.
3. Standard dilution on the microwell plate: Add 100 µl Assay Buffer (1x), in duplicate, to all standard wells leaving the first wells empty. Pipette 200 µl standard into the first wells and create standard dilutions by transferring 100 µl from well to well. Discard 100 µl from the last wells.
Alternatively external standard dilution in tubes (see 9.4.1): Pipette 100 µl of these standard dilutions in the microwell strips.
4. Add 100 µl Assay Buffer (1x), in duplicate, to the blank wells.
5. Add 80 µl Assay Buffer (1x) to sample wells.
6. Add 20 µl sample in duplicate, to designated sample wells.
7. Cover microwell strips and incubate 2 hours at room temperature (18° to 25°C).
8. Prepare HRP-Conjugate.
9. Empty and wash microwell strips 6 times with Wash Buffer.
10. Add 100 µl HRP-Conjugate to all wells.
11. Cover microwell strips and incubate 1 hour at room temperature (18° to 25°C).
12. Empty and wash microwell strips 6 times with Wash Buffer.
13. Add 100 µl of TMB Substrate Solution to all wells.
14. Incubate the microwell strips for about 10 minutes at room temperature (18° to 25°C).
15. Add 100 µl Stop Solution to all wells.
16. Blank microwell reader and measure colour intensity at 450 nm.

Note: If instructions in this protocol have been followed samples have been diluted 1:5 (20 µl sample + 80 µl Assay Buffer (1x)), the concentration read from the standard curve must be multiplied by the dilution factor (x 5).

Symbols / Symbole / Symbôles / Símbolos / Símbolos / Σύμβολα

	Cat.-No.: / Kat.-Nr.: / No.- Cat.: / Cat.-No.: / N.º Cat.: / N.-Cat.: / Αριθμός-Κατ.:
	Lot-No.: / Chargen-Bez.: / No. Lot: / Lot-No.: / Lote N.º: / Lotto n.: / Αριθμός -Παραγωγή:
	Use by: / Verwendbar bis: / Utiliser à: / Usado por: / Usar até: / Da utilizzare entro: / Χρησιμοποιείται από:
	No. of Tests: / Kitgröße: / Nb. de Tests: / No. de Determ.: / N.º de Testes: / Quantità dei tests: / Αριθμός εξετάσεων:
	Concentrate / Konzentrat / Concentré / Concentrar / Concentrado / Concentrato / Συμπύκνωμα
	Lyophilized / Lyophilisat / Lyophilisé / Liofilizado / Liofilizado / Liofilizzato / Λυοφιλιασμένο
	In Vitro Diagnostic Medical Device. / In-vitro-Diagnostikum. / Appareil Médical pour Diagnostics In Vitro. / Dispositivo Médico para Diagnóstico In Vitro. / Equipamento Médico de Diagnóstico In Vitro. / Dispositivo Medico Diagnostico In vitro. / Ιατρική συσκευή για In-Vitro Διάγνωση.
	Evaluation kit. / Nur für Leistungsbewertungszwecke. / Kit pour évaluation. / Juego de Reactivos para Evaluació. / Kit de avaliação. / Kit di valutazione. / Κιτ Αξιολόγησης.
	Read instructions before use. / Arbeitsanleitung lesen. / Lire la fiche technique avant emploi. / Lea las instrucciones antes de usar. / Ler as instruções antes de usar. / Leggere le istruzioni prima dell'uso. / Διαβάστε τις οδηγίες πριν την χρήση.
	Keep away from heat or direct sun light. / Vor Hitze und direkter Sonneneinstrahlung schützen. / Garder à l'abri de la chaleur et de toute exposition lumineuse. / Manténgase alejado del calor o la luz solar directa. / Manter longe do calor ou luz solar directa. / Non esporre ai raggi solari. / Να φυλάσσεται μακριά από θερμότητα και άμεση επαφή με το φως του ηλίου.
	Store at: / Lagern bei: / Stocker à: / Almacene a: / Armazenar a: / Conservare a: / Αποθήκευση στους:
	Manufacturer: / Hersteller: / Fabricant: / Productor: / Fabricante: / Fabricante: / Παραγωγός:
	Caution! / Vorsicht! / Attention! / ¡Precaución! / Cuidado! / Attenzione! / Προσοχή!
<p>Symbols of the kit components see MATERIALS SUPPLIED. Die Symbole der Komponenten sind im Kapitel KOMPONENTEN DES KITS beschrieben. Voir MATERIEL FOURNI pour les symbôles des composants du kit. Símbolos de los componentes del juego de reactivos, vea MATERIALES SUMINISTRADOS. Para símbolos dos componentes do kit ver MATERIAIS FORNECIDOS. Per i simboli dei componenti del kit si veda COMPONENTI DEL KIT. Για τα σύμβολα των συστατικών του κιτ συμβουλευτείτε το ΠΑΡΕΧΟΜΕΝΑ ΥΛΙΚΑ.</p>	

IBL AFFILIATES WORLDWIDE

	IBL International GmbH Flughafenstr. 52A, 22335 Hamburg, Germany	Tel.: + 49 (0) 40 532891 -0 Fax: -11 E-MAIL: IBL@IBL-International.com WEB: http://www.IBL-International.com
	IBL International B.V. Zuthpenseweg 55, 7418 AH Deventer, The Netherlands	Tel.: + 49 (0) 40 532891 -0 Fax: -11 E-MAIL: IBL@IBL-International.com WEB: http://www.IBL-International.com
	IBL International Corp. 194 Wildcat Road, Toronto, Ontario M3J 2N5, Canada	Tel.: +1 (416) 645 -1703 Fax: -1704 E-MAIL: Sales@IBL-International.com WEB: http://www.IBL-International.com

LIABILITY: Complaints will be accepted in each mode –written or vocal. Preferred is that the complaint is accompanied with the test performance and results. Any modification of the test procedure or exchange or mixing of components of different lots could negatively affect the results. These cases invalidate any claim for replacement. Regardless, in the event of any claim, the manufacturer's liability is not to exceed the value of the test kit. Any damage caused to the kit during transportation is not subject to the liability of the manufacturer